

# Chroma-Q™

## PS08

### User Manual



**Chroma-Q™**  
BRILLIANT SOLUTIONS

Version 1.3 September 2012  
PN: 139-0025



## Warranty Statement

Chroma-Q warrants to the original purchaser, with proof of purchase, that its delivered products shall be free from defects in material and workmanship under normal use for a period of 12 months from date of shipment.

Chroma-Q will repair, or at its option, provide an equivalent item or replace, the defective product during the stated warranty period. This warranty applies only to the repair or replacement of the product and only when the product is properly handled, installed and maintained according to Chroma-Q instructions. This warranty excludes defects resulting from improper handling, storage, installation, acts of God, fire, vandalism or civil disturbances. Purchaser must notify Chroma-Q in writing within 14 days of noticing the defect. This warranty excludes field labour or service charges related to the repair or replacement of the product.

The warranty contained herein shall not extend to any finished goods or spare parts from which any serial number has been removed or which have been damaged or rendered defective (a) as a result of normal wear and tear, willful or accidental damage, negligence, misuse or abuse; (b) due to water or moisture, lightning, windstorm, abnormal voltage, harmonic distortion, dust, dirt, corrosion or other external causes; (c) by operation outside the specifications contained in the user documentation; (d) by the use of spare parts not manufactured or sold by Chroma-Q or by the connection or integration of other equipment or software not approved by Chroma-Q unless the Customer provides acceptable proof to Chroma-Q that the defect or damage was not caused by the above; (e) by modification, repair or service by anyone other than Chroma-Q, who has not applied for and been approved by Chroma-Q to do such modification, repair or service unless the Customer provides acceptable proof to Chroma-Q that the defect or damage was not caused by the above; (f) due to procedures, deviating from procedures specified by Chroma-Q or (g) due to failure to store, install, test, commission, maintain, operate or use finished goods and spare parts in a safe and reasonable manner and in accordance with Chroma-Q's instructions (h) by repair or replacement of engines without factory training.

The warranty contained herein shall not apply to finished goods or spare parts which are sold "as is", as "second-hand", as used", as "demo" or under similar qualifications or to Consumables ("Consumables" is defined as any part(s) of goods or part(s) for use with goods, which part(s) of goods or part(s) for use with goods are consumed during the operation of the goods and which part(s) of goods or part(s) for use with goods require replacement from time to time by a user such as, but not limited to, light bulbs).

The warranty contained herein shall not apply, unless the total purchase price for the defective finished goods or spare parts has been paid by the due date for payment.

The warranty contained herein applies only to the original purchaser and are not assignable or transferable to any subsequent purchaser or end-user.

This warranty is subject to the shipment of the goods, within the warranty period, to the ChromaQ warranty returns department, by the purchaser, at the purchasers expense. If no fault is found, ChromaQ will charge the purchaser for the subsequent return of the goods.

Chroma-Q reserves the right to change the warranty period without prior notice and without incurring obligation and expressly disclaims all warranties not stated in this limited warranty.

## Disclaimer

The information contained herein is offered in good faith and is believed to be accurate. However, because conditions and methods of use of our products are beyond our control, this information should not be used in substitution for customer's tests to ensure that Chroma-Q products are safe, effective, and fully satisfactory for the intended end use. Suggestions of use shall not be taken as inducements to infringe any patent. Chroma-Q sole warranty is that the product will meet the sales specifications in effect at the time of shipment. Your exclusive remedy for breach of such warranty is limited to refund of purchase price or replacement of any product shown to be other than as warranted.

Chroma-Q reserves the right to change or make alteration to devices and their functionality without notice due to our on going research and development.

The Chroma-Q PS08 has been designed specifically for the professional entertainment lighting industry. Regular maintenance should be performed to ensure that the products perform well in the entertainment environment.

If you experience any difficulties with any Chroma-Q products please contact your selling dealer. If your selling dealer is unable to help please contact [support@chroma-q.com](mailto:support@chroma-q.com). If the selling dealer is unable to satisfy your servicing needs, please contact the following, for full factory service:

**Outside North America:**

Tel: +44 (0)1494 446000

Fax: +44 (0)1494 461024

[support@chroma-q.com](mailto:support@chroma-q.com)

**North America:**

Tel: 416-255-9494

Fax: 416-255-3514

[support@chroma-q.com](mailto:support@chroma-q.com)

For further information please visit the Chroma-Q website at [www.chroma-q.com](http://www.chroma-q.com).

Chroma-Q is a trademark, for more information on this visit [www.chroma-q.com/trademarks](http://www.chroma-q.com/trademarks).

The rights and ownership of all trademarks are recognised.

## Approvals



## Table of Contents

1.	Product Overview	.....	4
2.	Operation	.....	4
	Power		
	Data		
	Termination		
	Indicators		
	System Diagram		
	Load		
	Power Units		
	Installation		
	Compatibility		
	Control and Power Cables		

## 1. Product overview

The Chroma-Q PS08 supplies power and data to the Chroma-Q range of colour changers and compatible products (see below). A maximum capacity of 8PU (Power Units), it can be controlled remotely via ANSI E1.1 USITT DMX 512-A and delivers power and data via 2 XLR-4 outputs.

## 2. Operation

### Power

Connect power through a fused male IEC chassis connector with input power of 100-240V, 50-60 Hz. The standard fuse is a 5x20mm 3A GMA. It provides 2 circuits of combined 24VDC.

### Data

Data input ANSI E1.1 USITT DMX 512-A from an external source or lighting control console connects through a male XLR-5. A pass through connection is available on the female XLR-5.

Connect power and data from the female XLR-4 outputs of the PS08 to the colour changer units.

### Termination

Data termination is built in at the input.

### Indicators

The red LED indicates mains power is present and the green LED indicates a DMX signal is present.

### System Diagram

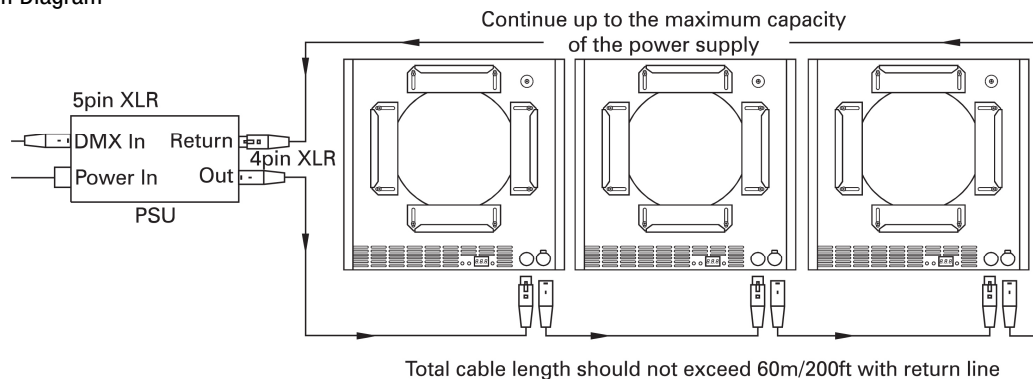

The PS-08 has been designed for cable loops of up to 60m/200ft per output. Closing the loop with a return cable will enhance the stability of the power delivered and connected to your data line.

### Load

To simplify the choice of power supply we use the "PU" (Power Unit) to calculate the load requirements of the Chroma-Q system. The PS08 will supply up to 8 PU's, so you can plug-in 8 Chroma-Q Plus (8 x 1PU = 8PU).

### Power Units

Chroma-Q Product	Power Unit
Plus	1 PU
Broadway	1 PU
Cascade	1.5 PU
Universal	1.5 PU
M5	1.5 PU
M8	1.5 PU
Moving Mirror	1 PU
DMX Gobo Rotator	0.6 PU

### Installation

The Chroma-Q PS08 is designed to be screwed on to set or hung from truss. The L-shaped bracket has multiple fixing slots to accept standard hook clamps or half couplers. Ensure adequate ventilation around the holes on the enclosures. Inadequate ventilation may result to premature failure of the unit.

### Compatibility

The Chroma-Q PS08 is compatible with all Chroma-Q Colour Changers - Chroma-Q Plus, Original, Broadway, Universal, Cascade, M5, M8, Moving Mirror, Twin Gobo Rotator, Twin Effects Gobo Rotator, Twin DMX Gobo Rotator.

### Control and Power Cables

The Chroma-Q utilises an XLR-4 pin cable system. This is used to supply power and data transfer. Pins 1 and 4 supply 24VDC power and pins 2 and 3 supply ANSI E1.11 USITT DMX512-A control protocol with a ground drain wire to the connector shell.

Only genuine Tourflex Datasafe Cable is recommended for use of the Chroma-Q colour changing system.

Damage will occur if the power connections short circuit to the data or ground/shield connections. When assembling XLR4-pin cables, heat shrink sleeves should be used on each individual data pin and the drain wire to prevent short circuits.

The XLR-4 cable is wired pin to pin, in the following format:

Pin #	Function
1	0V DC
2	Control data minus
3	Control data plus
4	+24V DC
Chassis	Ground bonding

The XLR-5 cable is wired pin to pin, in the following format:

Pin #	Function
1	Ground (screen)
2	Data minus
3	Data plus
4	Spare data minus
5	Spare data plus