

## Approvals & Disclaimer



The information contained herein is offered in good faith and is believed to be accurate. However, because conditions and methods of use of our products are beyond our control, this information should not be used in substitution for customer's tests to ensure that Chroma-Q products are safe, effective, and fully satisfactory for the intended end use. Suggestions of use shall not be taken as inducements to infringe any patent. Chroma-Q sole warranty is that the product will meet the Chroma-Q sales specifications in effect at the time of shipment. Your exclusive remedy for breach of such warranty is limited to refund of purchase price or replacement of any product shown to be other than as warranted.

Chroma-Q reserves the right to change or make alteration to devices and their functionality without notice due to on-going research and development.

The Chroma-Q Color Web has been designed specifically for the professional entertainment lighting industry. Regular maintenance should be performed to ensure that the products perform well in the entertainment environment.

If you experience any difficulties with any Chroma-Q products please contact your selling dealer. If your selling dealer is unable to help please contact [support@chroma-q.com](mailto:support@chroma-q.com). If the selling dealer is unable to satisfy your servicing needs, please contact the following for full factory service:

### Outside North America:

Tel: +44 (0)1494 446000

Fax: +44 (0)1494 461024

[support@chroma-q.com](mailto:support@chroma-q.com)

### North America:

Tel: +1 416-255-9494

Fax: +1 416-255-3514

[support@chroma-q.com](mailto:support@chroma-q.com)

For further information please visit the Chroma-Q website at [www.chroma-q.com](http://www.chroma-q.com).

Chroma-Q is a trademark, for more information on this visit [www.chroma-q.com/trademarks](http://www.chroma-q.com/trademarks).

The rights and ownership of all trademarks are recognised.

# Quick Start Guide

## Color Web™ 250

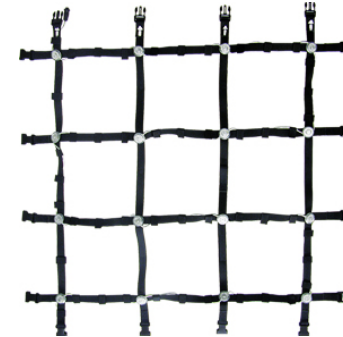

For a full product manual please visit [www.chroma-q.com](http://www.chroma-q.com)

## 1. Equipment Overview

**Color Web 250 panel** – each Color Web panel is made up of 16 LED nodes. This starts in the top left and snakes down to the bottom left. Each LED has its own DMX address and this is assigned depending on which output from the PSU it is plugged into.

**Color Web PSU10DMX** – will run 10 x Color Web 250 panels. It takes an IEC mains connection at one end and a DMX in and thru at the other. On the front is a multi-pin connection for the spider. As each PSU takes 480 channels of DMX per 10 channels, each one is factory set to DMX address 001.

**Color Web Spiders** – the spider plugs into the PSU and has 5 x 1m leads with 4 pin connectors on the end. Each output is marked with white plastic rings, one thru five.

**Extension Cables** – available in 1m, 2m, 3m and 4m lengths, used to extend cable runs from the spider to the panels.

**Multicore** – available in 5m and 10m and run in between the PSU and spider.

**Fly Adapters** – used to attach the panels to a hanging point, eg pipe or truss. There are two connection lengths per fly adapter, allowing a 576mm drop and 451mm drop suitable for double hanging. After a 10m drop a secondary fixing is required on the back of the web.

**IP65 End Caps** – the Color Web is IP65 rated, however any connectors not in use are not. The end caps protect the exposed connectors to an IP65 rating.

## 2. Connecting the System

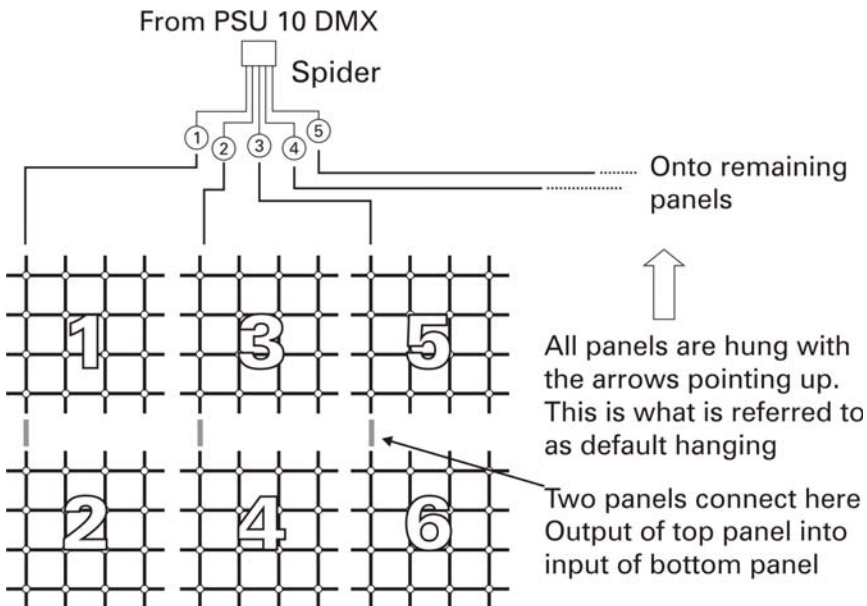

## 3. Patching

Panel Number	DMX Address	Spider Output
1	1	1
2	49	Linked to panel 1
3	97	2
4	145	Linked to panel 3
5	193	3
6	241	Linked to panel 5
7	289	4
8	337	Linked to panel 7
9	385	5
10	433	Linked to panel 9

## 4. Default Panel Layout

