

Installation Guide

Chroma-Q® 2inspire™

C RING AND DIFFUSER KIT



Chroma-Q®
BRILLIANT SOLUTIONS

For a full product manual please visit www.chroma-q.com

For use with

Part Number: CQ1509-9151, CQ1509-9156, CQ1509-9161, CQ1509-9166,
CQ1509-9251, CQ1509-9256, CQ1509-9261, CQ1509-9266,
CQ1509-9351, CQ1509-9356, CQ1509-9361, CQ1509-9366,
CQ1509-9171, CQ1509-9172, CQ1509-9271, CQ1509-9272
CQ1509-9371, 1509-9372

Model: 1509-9151, 1509-9156, 1509-9161, 1509-9166,
1509-9251, 1509-9256, 1509-9261, 1509-9266,
1509-9351, 1509-9356, 1509-9361, 1509-9366,
1509-9171, 1509-9172, 1509-9271, 1509-9272
1509-9371, 1509-9372

Installation Procedure

For the 2inspire™ IP 20 fixtures, insert the diffusion filter first, it might need to be slightly bent to insert.

Next, insert the C ring to lock the diffusion filter in place.

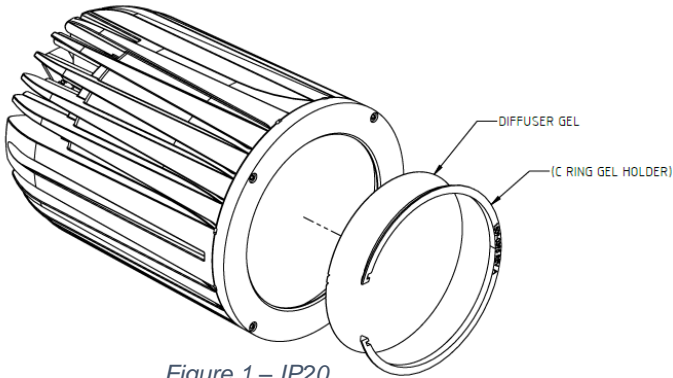

Figure 1 – IP20

To install or change a diffusion filter on the IP 65 version, the front bezel must be removed and the diffusion gel inserted between the glass and the lens. Only the Chroma-Q original diffusion gel are approved to be used.

The four screws on bezel need to be reinstalled with a torque of 1.45 Nm (12.83 in-lb) for 2inspire™ 100 and 1.6 Nm (14 in-lb) for 2inspire™ 200/300 to ensure complete tightness preventing any environmental exposure of the fixtures.

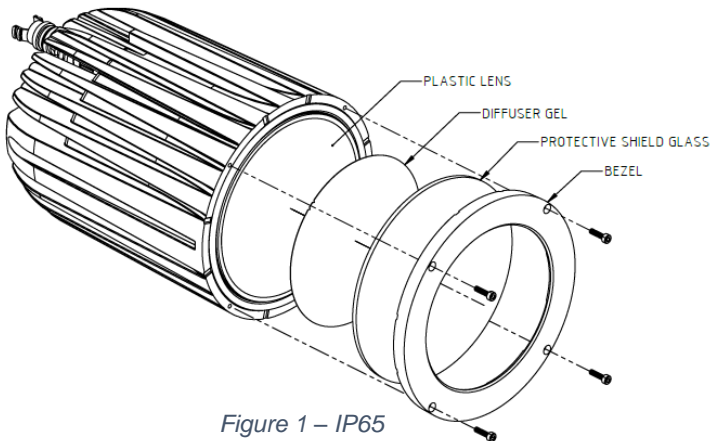
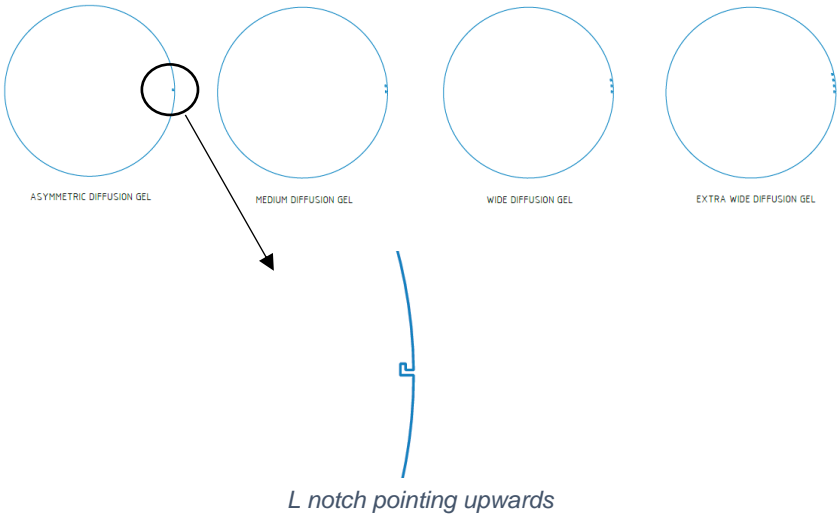

Figure 1 – IP65

Patterns and Orientation for diffusers



The shiny surface should be facing down towards the Lens of the fixture

Disclaimer

Dimensions and illustrative drawings contained herein are accurate to the company's knowledge at the time of printing, however specifications are subject to change without notice.

Further Information

Please refer to the Chroma-Q 2inspire™ Manual for more detailed information about the fixture. A copy of the manual can be found at the Chroma-Q website – <http://www.chroma-q.com/support/downloads.asp>

Approvals & Disclaimer



The information contained herein is offered in good faith and is believed to be accurate. However, because conditions and methods of use of our products are beyond our control, this information should not be used in substitution for customer's tests to ensure that Chroma-Q products are safe, effective, and fully satisfactory for the intended end use. Suggestions of use shall not be taken as inducements to infringe any patent. Chroma-Q sole warranty is that the product will meet the Chroma-Q sales specifications in effect at the time of shipment. Your exclusive remedy for breach of such warranty is limited to refund of purchase price or replacement of any product shown to be other than as warranted.

Chroma-Q reserves the right to change or make alteration to devices and their functionality without notice due to on-going research and development.

The Chroma-Q 2inspire™ has been designed specifically for the lighting industry. Regular maintenance should be performed to ensure that the products perform well in the entertainment environment.

If you experience any difficulties with any Chroma-Q products please contact your selling dealer. If your selling dealer is unable to help please contact support@chroma-q.com. If the selling dealer is unable to satisfy your servicing needs, please contact the following for full factory service:

Outside North America: North America:
Tel: +44 (0)1494 446000 Tel: +1 416-255-9494
Fax: +44 (0)1494 461024 Fax: +1 416-255-3514
support@chroma-q.com support@chroma-q.com

For further information please visit the Chroma-Q website at www.chroma-com.

Chroma-Q is a trademark, for more information on this visit www.chroma-q.com/trademarks.

The rights and ownership of all trademarks are recognized.